

SEEBURG

TORMAT ELECTRICAL SELECTOR

TYPE TES107

SEEBURG

TORMAT ELECTRICAL SELECTOR, Type TES107

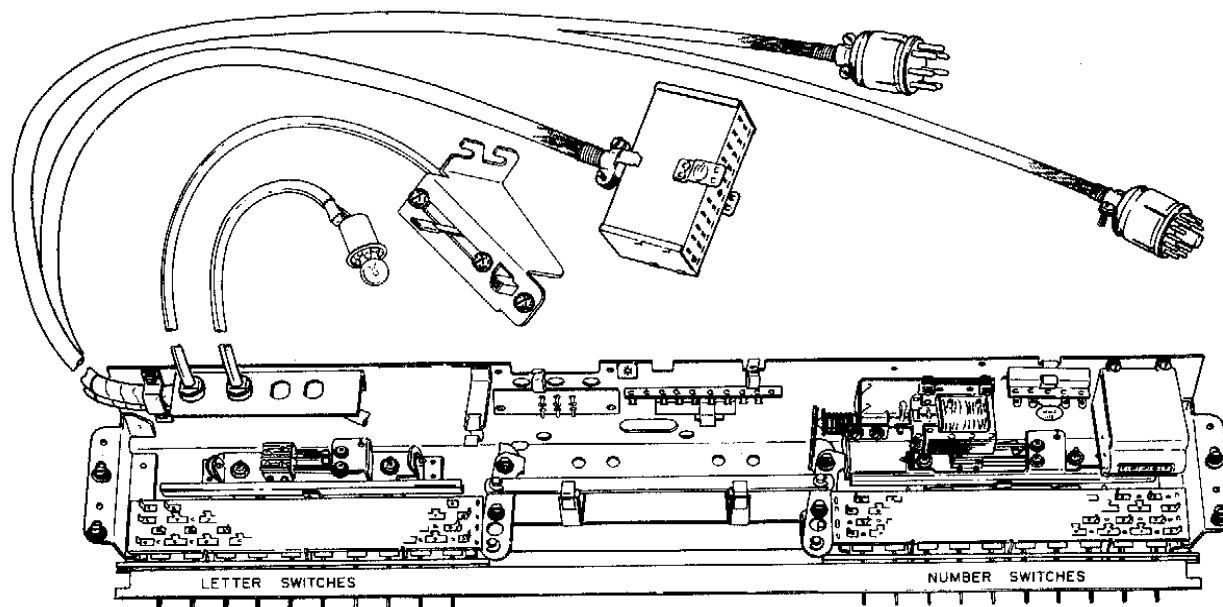

The Tormat Electrical Selector, Type TES107, is part of the Seeburg Tormat Selection System. The principal functions of the selector are to connect a letter and a number circuit of the Tormat Memory Unit of the system into a selection write-in circuit and to complete a circuit that initiates the operational sequence of the system. These are performed when operating a lettered selector key and a numbered key.

The principal component parts of the selector include the service switch, two selection switch assemblies, a latch bar operating solenoid, credit indicating light, a credit lamp terminal board and two switch groups each of which has two pairs of contacts. There is also a counter which totals the number of selections made with remote control Wall-O-Matics as well as those made with the Electrical Selector.

The credit indicating light is extended on its connecting leads so it illuminates the selection information window that is in the phonograph. It is a 6-volt lamp operated at 25 volts through a 65-ohm resistor.

The latch bar function is to hold in a selection switch (and selector key) when a selection is being made and to release it when the selection is complete. The solenoid is energized when credits are set up in the phonograph.

The shafts of the selector switches operate treadle bars when a selector key is pressed and the treadle bars, in turn, operate switch groups consisting of a spring-leaf switch and a snap-

action, over-center switch. One switch group is associated with each of the selection switches. The spring-leaf switches are parallel connected and are part of a timing relay holding circuit that is completed through interlocking contacts on the relay when any selector key is pressed. These switches are the Hold Switches, contacts X and W.

The snap-action switches are the Starting Switches, contacts Y and Z. The Z contacts close when a letter selector key is pressed. The Y contacts are closed by pressing a number selector key and are in series with the Z contacts. These contacts are part of a circuit that includes a Subtract, or Cancel Solenoid in the phonograph Universal Pricing Unit. When a letter key and a number key are pressed, the starting switches complete the circuit to the solenoid which, when energized, closes switch contacts that control the power to the Tormat Memory Unit, the selection counter and the timing relay. They also close, momentarily, the circuit for a play control add solenoid that, in turn, controls, through a play control unit, the power to the phonograph amplifier and the mechanism motor.

The credit light and "starting" circuits of the selection system are not the same for Dual and Single Pricing. These circuits are connected to suit the pricing unit with which the phonograph is equipped.

When dual pricing is used, an E.P. Assembly

TORMAT ELECTRICAL SELECTOR, Type TES107

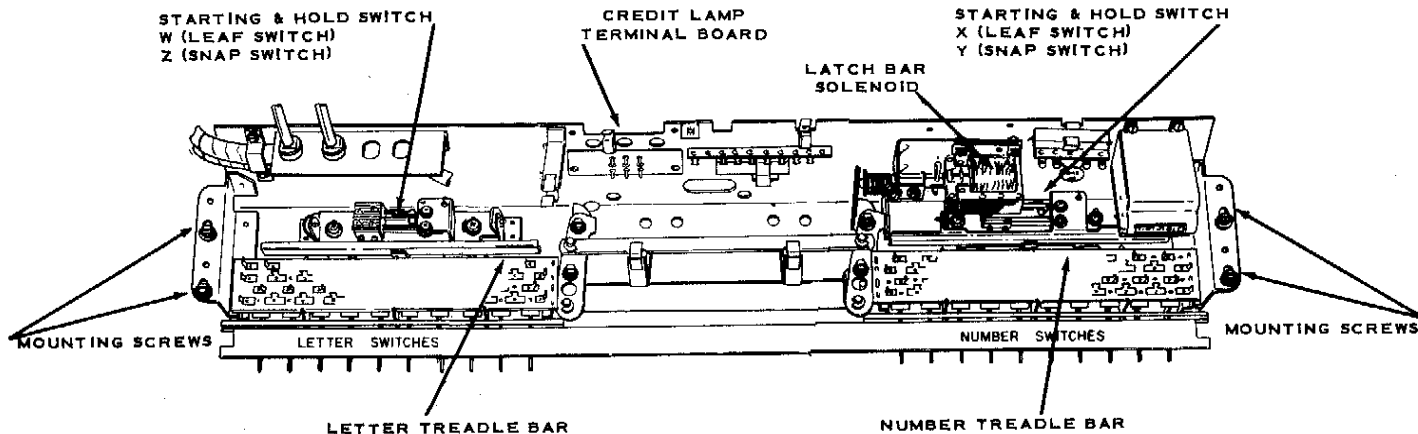



is installed in the Universal Pricing Unit of the phonograph and an E.P. Treadle and Switch Assembly is installed in the Electrical Selector. The switch of this assembly, S369, is in the "starting" circuit of the Electrical Selector. It is normally closed and connecting the starting circuit to the subtract solenoid in the Universal Dual Pricing Unit. Tabs on the E.P. Treadle may be positioned to actuate the switch when a

letter selector button (A to K) is pressed. The switch transfers the starting circuit to the E.P. subtract solenoid thus providing for E.P. pricing.

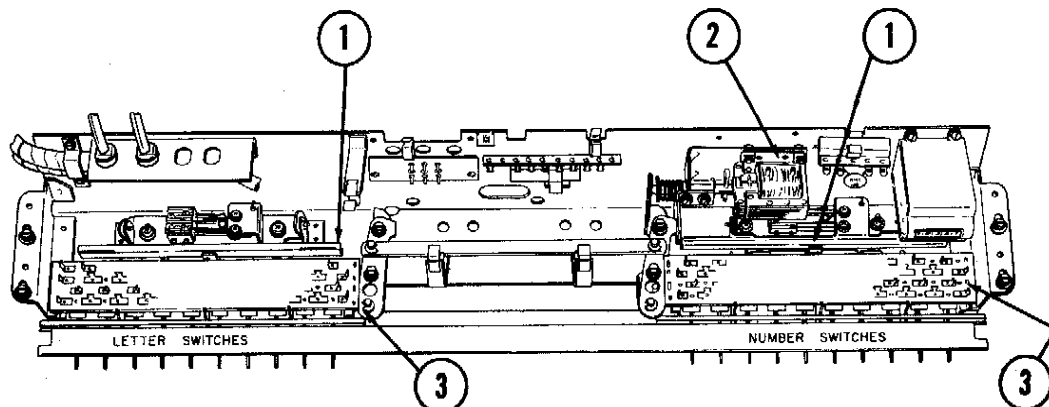
When dual pricing is used, two additional indicating lights are connected to the Credit Lamp Terminal Board to indicate 5 cents credit, 10 cents credit and "Make Any Selection".



① TREADLE BAR SPRINGS

4 1/2 - 5 1/2 OZ.

FORCE TO MOVE TREADLE BARS FROM NORMAL REST POSITION (AGAINST RUBBER STOPS).

② LATCH RELEASE LEVER SPRING

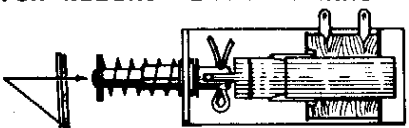

RESTRAIN MOVEMENT OF NUMBER RELEASE LEVER - FORCE TO START MOVEMENT OF SOLENOID ARMATURE IS THEN 5 TO 7 OZ.

③ LATCH BAR SPRING



6 TO 7 OUNCES HERE TO START MOVEMENT.

TORMAT ELECTRICAL SELECTOR, Type TES107

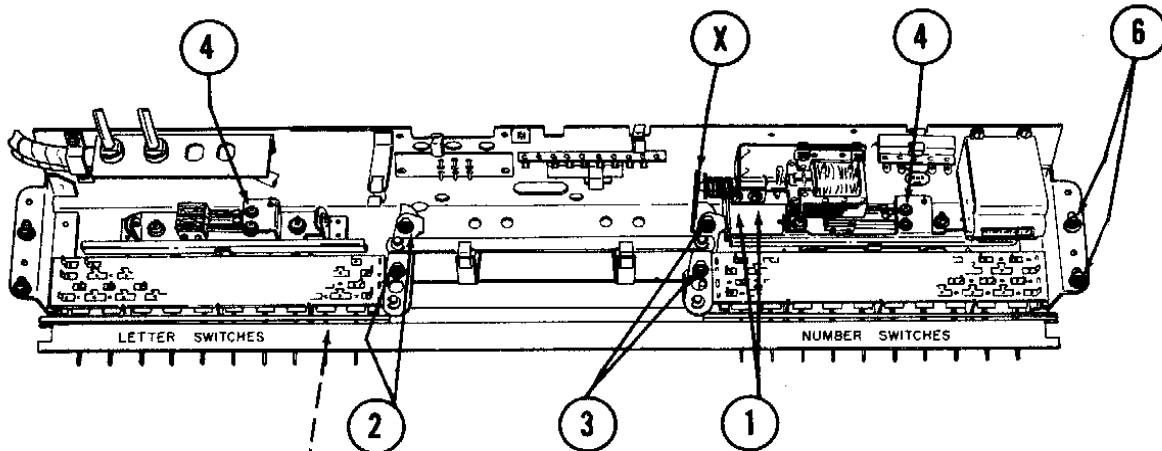

NOTE: Adjustments 1, 2 and 3 to be made in sequence with latch bar solenoid in energized position.

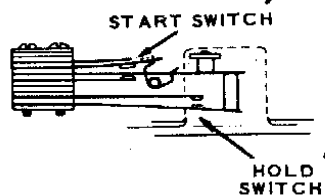
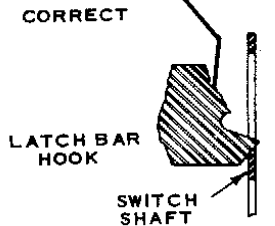
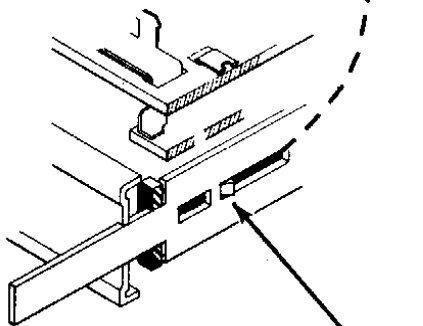

- 1 Adjust latch lever bracket position for latch bar engagement of NUMBER SWITCHES.
- 2 Adjust letter switch lever position for latch bar engagement of LETTER SWITCHES.
- 3 Adjust number switch latch lever for 1/32" minimum gap at X with solenoid energized.
- 4 Adjust snap action START SWITCHES by positioning the brackets for the entire switch stack. START SWITCH should close when the selector switches have approximately 1/32" more travel before latching by latch bars.
- 5 Adjust Hold Switch by bending blades AFTER Start Switch has been correctly set. Hold Switch to close before Start Switch closes and open after Start Switch opens. Contact gap 1/64" to 1/32".
- 6 Loosen two mounting screws at each end to position Selector so selection switches release fully with minimum clearance between ends of switch shafts and backs of selector keys.

TORMAT ELECTRICAL SELECTOR, Type TES107

Dwg. No. 411468

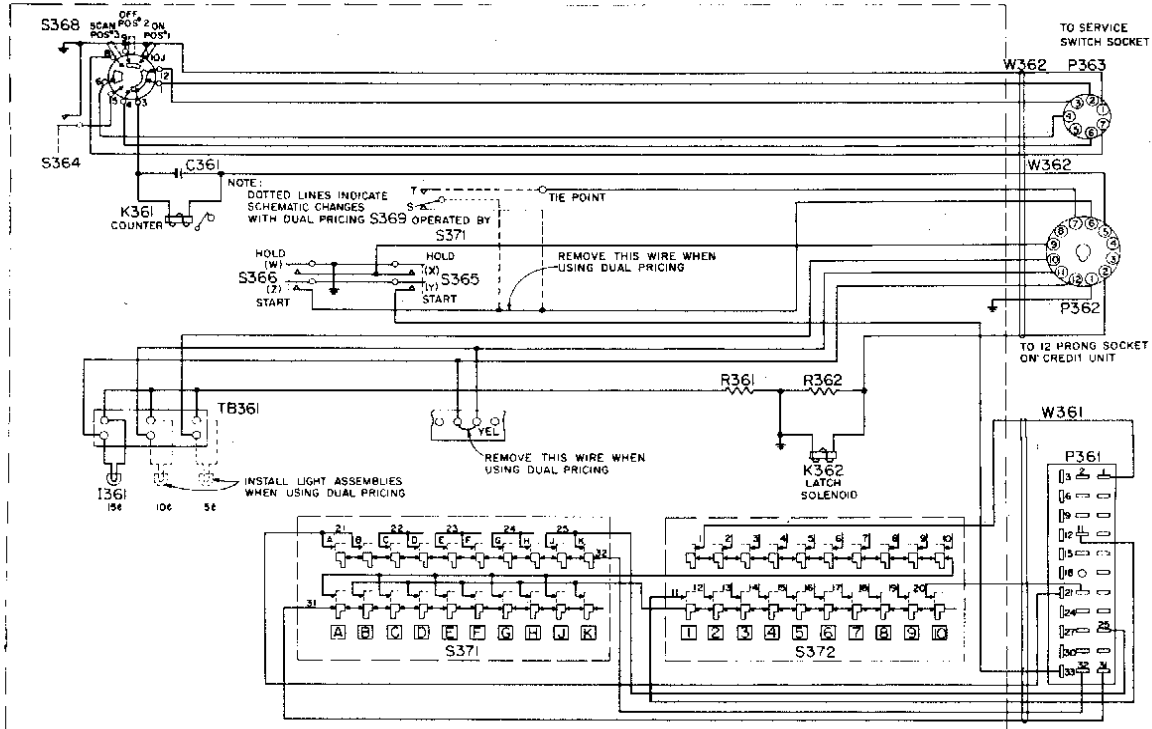

DUAL PRICING SWITCH ADJUSTMENT

NOTE: EP treadle and switch are used when the electrical selector is set up for dual pricing.

With no selector switches operated, set up gaps as shown.

A With an EP tab in the down (selected) position, operate selector switch, note that "T" makes and "S" breaks before start switch operates (*this is important*). Gap at "S" should be approximately 1/8 inch.

B Contact pressures as follows:

"S" - 1½ oz.

At "T", with selector switch stem latched in, 2 oz. minimum.

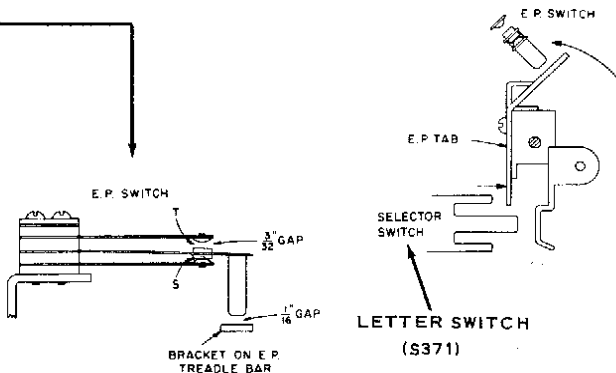

PARTS LIST

Item	Part No.	Description
-	411028	Tormat Electrical Selector, TES107
C361	86259	0.02 mfd. Ceramic
I 361	410823	Credit Lamp Socket Assembly
K361	411082	Counter Assembly
K362	410726	Latch Solenoid
P361	410608	Socket Assembly
P362	410708	12 Prong Plug
P363	408258	7 Prong Plug
R361	81178	65 ohm 10 watt
R362	81183	100 ohm 10 watt
S364	305635	Credit Switch
S365	411073	Snap Switch
S366	411073	Snap Switch
S368	411278	Service Switch
S369	411383	Dual Pricing Switch
S371	411290	Selector Switch (Letters)
S372	411207	Selector Switch (Numbers)
TB361	411353	Terminal Board
W361	411292	Matrix Cable
W362	411433	Control Cable